

Cultured Marble Vanity Tops Made in the USA

P.O. Box 378, 3125 Riley Road, Sparta, Wisconsin • Phone 888-664-7465 • Fax 608-366-1934 • www.sinksbySfi.com



Venetian^{by Sfi}

111 Wave Bowl — Architectural Specifications



* Standard overflow

Product Measurements:

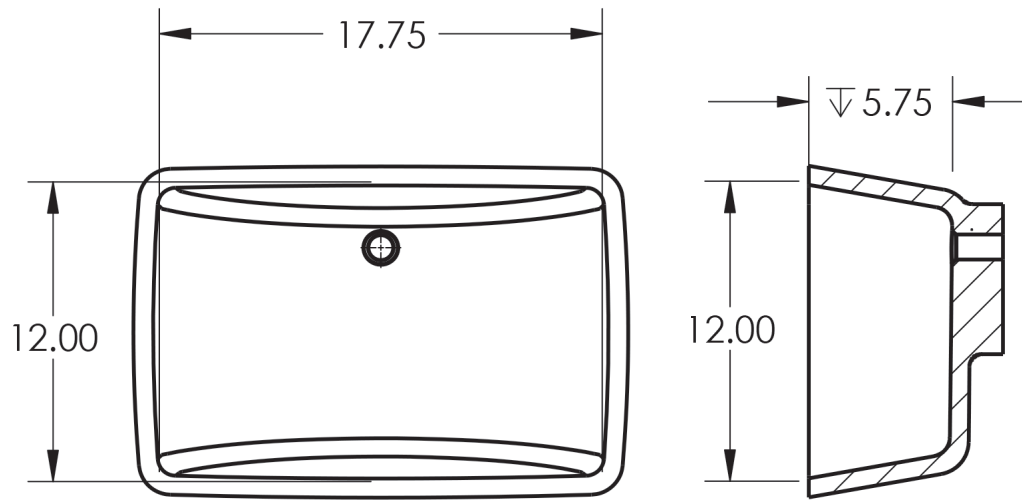

Color Options:



| | | | | | | | | |
|-----------------------|-------------------|----------------|---------------|---------------------|----------------|--------------------------|-------------------------|--------------|
| 1001 White / White | 1003 Lt. Taupe | 1007 Coffee | 1009 Linen | 1009B Pure Linen | 1016 Frappe | 1026 White on Sandbar | 1027 White on Silver | 1101 Snow |
|-----------------------|-------------------|----------------|---------------|---------------------|----------------|--------------------------|-------------------------|--------------|

Other colors are available for an upcharge

Product Description — The Venetian line is a high quality, custom cultured marble product line. The main body of the sink is a normal casting material. A gel coat top layer is chemically fused to the main body of the cast material. Venetian tops feature a 3/4" thick deck, integral backsplash (4" taller than the deck), and integral bowl. Optional bowl (SFI's 111 Wave) is a rectangular option (see above bowl specifications). Standard edge is slightly-eased. Standard depth is 22" and minimum depth is 18-1/2". Each color is custom poured and produces a marble-style look, available in a matte or gloss finish.

Performance — Venetian is resistant to heat, stains and mildew. Incidental damage such as scratches, marring, small stains, etc. can be repaired. (See Care and Cleaning and Repair and Maintenance instructions.) Venetian meets the ANZI 124.3 standards.

Colors and Finishes — Venetian is available in a full range of colors and is available in a matte or gloss finish. All colors can be viewed on our web site at www.sinksbySfi.com, but hold and look at an actual color sample before making your final color choice.

Limited Warranty — Venetian is covered by a one year limited warranty. Refer to the separate Venetian Limited Warranty sheet for complete details.

Contact — SFI, inc. Sales – include project name, funding agency, and required forms with your request.

SFI, Inc. Cast Polymer (Cultured Marble) Specifications

Includes: Full CSI 3-Part Spec, BABA/BABAA Notes, and SFI Color List

Section 06 61 19 – Cast Polymer Fabrications (Cultured Marble)

SFI, Inc. Proprietary Specification (No Substitutions) — 1-Year Warranty

Part 1 – General

1.1 Summary: Cast polymer cultured marble vanity tops with integral bowl, side splashes, aprons, shower/tub surrounds, shower base, shower accessories and windowsills.

1.2 References: Provide Lavatory tops and sinks that conform to ANSI Z1243-2005 when tested in the following areas:

- Color fastness – No change, 200 hours
- Wear and Cleaning – Passes
- Impact resistance – Passes
- Stain Resistance – Passes
- Chemical Resistance – Passes
- Drain Fitting Connection – Passes
- Loads on Lavatory Tops – Passes
- Thermal Shock Resistance – Passes
- Cigarette Burn Test – Passes

1.3 Definitions: Cultured marble/cast polymer description. Factory gel coat wear surface. Minimum of 23% polyester resin with calcium carbonate filler cast material.

1.4 Admin: Pre-installation conference at site \geq 5 weeks prior to start; review substrates, sequencing, interfaces, and protection.

1.5 Submittals: SFI Product Data Sheet, Shop Drawings, Samples (6"x6" color and pattern chips), Informational: fire test certificates (if Class A required), qualifications, BABA docs. Closeout: installation, maintenance data, and warranty.

1.6 Quality Assurance: Manufacturer 1 year, Installer \geq 2 years; provide mock-ups (vanity and typical surround).

1.7 Delivery, Storage and Handling: Deliver in original packaging; protect material, store flat, temp controls.

1.8 Field Conditions: Install only after enclosure, maintain 60-85F and RH $<$ 65% during work and adhesive cure.

1.9 Coordination: Coordinate faucet holes, drains/traps, blocking with Division 22 and Divisions 06.

1.10 Warranty: Standard SFI, Inc. Venetian line limited one year warranty against material and craftsmanship defects. Standard SFI, Inc. Roma line limited five year warranty against material and craftsmanship defects.

1.11 Regulatory: Comply with BABA/BABAA domestic content requirements unless waived by agency.

Part 2 – Products

2.1 Manufacturer: SFI, Inc. — Proprietary; Substitutions Not Permitted. Provide all vanity tops with sinks from a single source.

2.2 Materials: Composition-mineral filler with no less than 23% unsaturated polyester modified resin; UV stable pigments; factory gel coat on exposed faces within the range of 18-23 1/1000". Physical Properties – ASTEM E84 classification as required by code (Class A where indicated); nonporous polyester gel coat suitable for wet areas; thickness: 3/4" (19mm) vanity tops, 1/4" – 3/8" wall panel.

2.3 Color and Finish: SFI standard project colors: Snow, White/White, Frappe, Coffee, White on Silver, Light Taupe, Linen, White on Sandbar, Pure Linen. Polished Gloss or matte finish per approved sample.

2.4 Fabrication: Factory cast to sizes; provide integral/applied edges, integral back-splashes, integral bowl where scheduled; tolerances \pm 1/8" (dims), \pm 1/8" (openings); factory cutouts where specified.

2.5 Accessories: Manufacturer recommended low VOC panel/structural adhesives; 100% silicone mildew resistant sealant; corrosion resistant fasteners and anchors.

2.6 Source Quality Control: Visual quality – free of pinholes, crazing, blisters, chips, inconsistent color/veining when viewed at 5'; provide fire test reports if Class A specified and BABA documentation when applicable.

Part 3 – Execution

3.1 Examination: Verify substrates are plumb/true within 1/8" in 8'; clean/dry and free of contaminants; do not start until deficiencies are corrected.

3.2 Preparation: Provide blocking for panel terminations, seats, and accessories; dry fit; confirm joints and field cuts before adhesive use.

3.3 Installation: Install per SFI instructions and approved shop drawings; align/level/shim/scribe; maintain uniform joints. Panels-apply adhesives in ribbons; set with even pressure; seal corners/vertical joints with silicone; maintain penetrations clearances and seal watertight. Vanity tops-set on level supports with adhesive dabs; provide continuous support; seal back-splashes and interfaces, side splashes if scheduled. Receptors-install over approved bases or mortar beds; connect to drains per Division 22; maintain slopes.

3.4 Field Quality Control: Correct damage, lippage $>$ 1/8" (2 mm), open seams, or incomplete sealant.

3.5 Cleaning: Remove excess adhesives/sealants; clean with vinegar (not to exceed 5%) and water.

3.6 Protection: Protect finished surfaces with manufactures protective plastic. Do not set any items on the top once installed; replace damaged work.

BABA/BABAA Coordination Notes

These notes assist coordination for federally assisted projects. Where applicable, SFI will provide manufacturer certificate (s) and step documentation confirming domestic production status for covered categories.

Scope: BABA applies a domestic content preference to iron, steel, manufactured products, and construction materials use din covered infrastructure projects (obligations after May 14, 2022).

Applicability: Buildings and facilities that serve a public function may be covered; confirm with Owner/funding agency.

Category: SFI cultured marble components are typically treated as manufactured products; confirm category and documentation with funding agency.

Documentation: From SFI – (a) manufacturer certificate of compliance, (b) step/trace documentation as required by agency, (c) identification of US manufacturing site(s).

Specification Placement: Put detailed BABA procedures in Division 01; reference them in Section 06 61 19 (see Part 1.11).

Waivers: If agency-approved (general, nonavailability, or project-specific), cite in Division 01 and include in closeout.

Checklist: (1) Confirm funding triggers; (2) Confirm category; (3) Define required documents; (4) Align submittal logs; (5) Retain certificates in closeout.

Distributor Information